

Superior³ Flexi Platform & Goods Lift

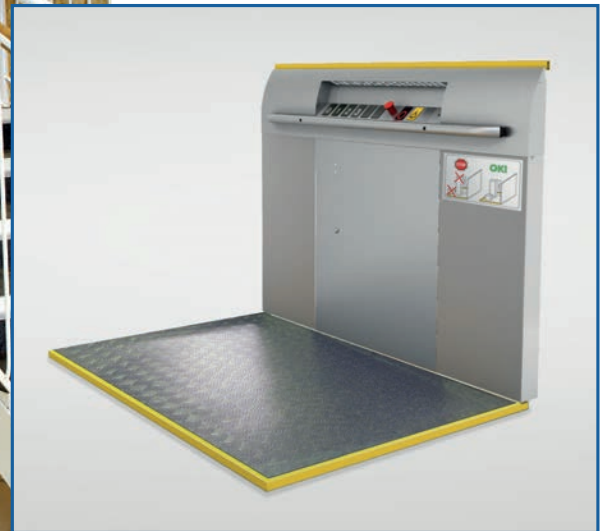

Variety of platform sizes and interior options available

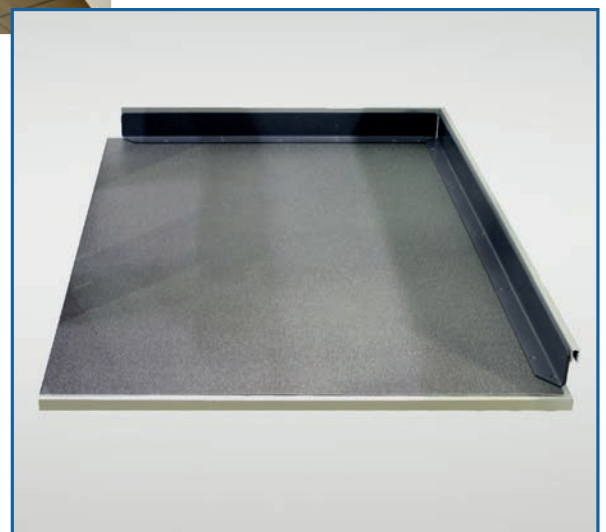

Optional steel kerbs on platform to protect shaft walls

Superior³ Flexi Platform & Goods Lift

This platform lift is suitable for installation into new buildings or for retrofitting into existing sites. The self-contained enclosure can be assembled within days, minimising disruption and builders works.

Advantages offered by the Superior³ Flexi Platform & Goods Lift include:

- Platform sizes and a variety of options tailored to public access environments
- 95% recyclable materials
- Patented screw/nut technology
- The lowest maintenance and operating costs on the market
- Minimum standby power of 15W
- No additional space required outside footprint of shaft
- Dual certified for use for disabled access and for the transportation of goods

Superior³ Flexi Platform & Goods Lift

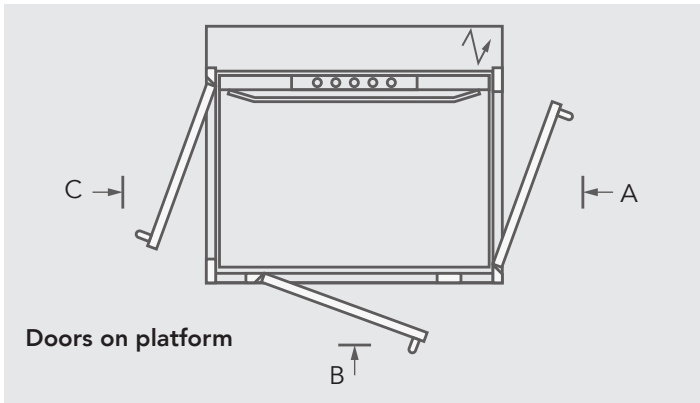

Platforms:	Available in 8 different sizes
Doors:	Entrances available on view A, B or C
Door hinge:	Doors can be left or right hinged
Pit depth:	50 mm (or with a ramp no pit is required)

Options Available

- Glass panels within shaft enclosure
- Any RAL colour powder coating to shaft and/or doors
- 180° open through and 90° adjacent entries or open front only
- Secure key switch operation
- Choice of emergency communication systems
- EI60 fire and smoke certified entrances
- Ramp, in lieu of forming 50 mm pit
- Ceiling with light unit and power saving shutdown feature
- Kerbs on platform to protect shaft walls
- Checker plate or studded rubber floor
- 1000 mm wide doors

Standards

The Superior³ Flexi Platform & Goods Lift complies with the requirements of the European Machinery Directive 2006/42/EC and European standard EN 81-41

Technical Specification

Rated load:	410 – 500 kg / 5 persons
Travel height:	250 – 13,000 mm
Number of stops:	Maximum 6 stops
Platform control:	'Hold to run' button must be kept pressed during travel
Landing control:	One-touch call and send facility
Rated speed:	Maximum 0.15 m/s
Control voltage:	24 V
Motor:	2.2 kW
Drive system:	Patented double safety screw/nut system
Environment:	Indoors or outdoors
Power supply:	415 V; 3 phase; 50 Hz as standard 230 V; single phase; 50 Hz optional (not for 500 kgs)
Emergency lowering:	Battery backed emergency lowering and release system, operated from platform or landing
Safety features:	Touch sensitive safety edge to all sides of platform Alarm sounder with battery back up

Landmark Lifts Limited

29 Charter Gate
Quarry Park Close
Moulton Park
Northampton
NN3 6QB
United Kingdom

t: 01604 671007

f: 01604 671017

e: info@landmarklifts.co.uk

w: www.landmarklifts.co.uk

Part of the NLC Nova Group

Our marketing literature is presented in good faith as a guide to represent the product offered and does not form a part of our contract.



Superior³ Flexi Platform & Goods Lift control panel