

Superior³ Platform Lift



Superior³ Platform Lift

This platform lift is suitable for installation into new buildings or for retrofitting into existing sites. The self-contained enclosure can be assembled within days, minimising disruption and builders works.

Advantages offered by the Superior³ include:

- Platform sizes and a variety of options tailored to public access environments
- 95% recyclable materials
- Patented screw/nut technology
- The lowest maintenance and operating costs on the market
- Minimum standby power of 15W
- No additional space required outside footprint of shaft

Superior³ Platform Lift

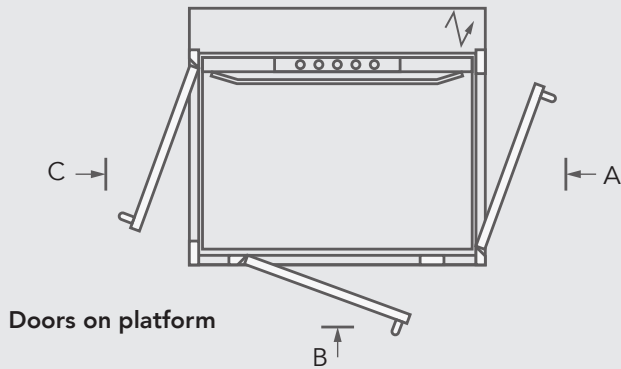

Platforms:	Available in 8 different sizes
Doors:	Passage available on view A, B or C
Number of doors:	Maximum 2 doors per floor
Door hinge:	Doors can be left or right hinged
Pit depth:	50 mm (or with a ramp no pit is required)

Options Available

- Glass panels within shaft enclosure
- Any RAL colour powder coating to shaft and/or doors
- 180° open through and 90° adjacent entries or open front only
- Secure key switch operation
- Choice of emergency communication systems
- EI60 fire and smoke certified entrances
- Ramp, in lieu of forming 50 mm pit
- Ceiling with light unit and power saving shutdown feature
- Full height wall with mirror and LED lights

Standards

The Superior³ Platform Lift complies with the requirements of the European Machinery Directive 2006/42/EC and European standard EN 81-41

Technical Specification

Rated load:	250 – 500 kg / 2 – 5 persons
Travel height:	250 – 13,000 mm
Number of stops:	Maximum 6 stops
Platform control:	'Hold to run' button must be kept pressed during travel
Landing control:	One-touch call and send facility
Rated speed:	Maximum 0.15 m/s
Control voltage:	24 V
Motor:	2.2 kW
Drive system:	Patented double safety screw/nut system
Environment:	Indoors or outdoors
Power supply:	415 V; 3 phase; 50 Hz as standard 230 V; single phase; 50 Hz optional
Emergency lowering:	Battery backed emergency lowering and release system, operated from platform or landing
Safety features:	Touch sensitive safety edge to all sides of platform Alarm sounder with battery back up



Superior³ Platform Lift control panel

Landmark Lifts Limited

29 Charter Gate
Quarry Park Close
Moulton Park
Northampton
NN3 6QB
United Kingdom

t: 01604 671007

f: 01604 671017

e: info@landmarklifts.co.uk

w: www.landmarklifts.co.uk

Part of the NLC Nova Group

Our marketing literature is presented in good faith as a guide to represent the product offered and does not form a part of our contract.