

Thorax Goods Lift



- Specifically designed to carry goods only, although we are able to offer the option for up to 2 trained operators to travel with the goods (not suitable for general passenger transport).
- It comes with its own self-supporting modular steel structure with primed (RAL 7032) sheet steel cladding. Suitable for use within a shaft construction or freestanding against a mezzanine floor. RAL colours available at additional cost.
- No additional space required outside the footprint of shaft. The unit is self contained with the motor located at the head of the shaft (removable access ladder supplied).
- Suitable for internal installation into existing buildings or new build projects.
- Minimal pit required, however we can provide a ramp.

Thorax Goods Lift

Type	Thorax
Capacity	500 / 1000 / 1500 / 2000 / 2500 kg
Speed	0.15 m/s.
Travel Distance	16 metres maximum
No of Stops	6 maximum (2 doors per floor)
Maximum No of Entrances	12
Shaft Finish	Grey primer RAL 7032
Shaft Construction	Self supporting modular steel panel shaft construction. Non fire rated. Stainless steel finish available at extra cost.
Pit Depth	100 - 130 mm
Headroom Requirement	2650 mm above finished floor at upper level served plus 250 mm free working space and for use of lifting beam
Configuration	Open front or open through
Doors	Double or single panelled manually operated hinged doors with vision panel (dependent upon size of lift)
Door Dimensions	1000 - 2000 mm (see above)
Door Height	1900 - 2500 mm available (2000 mm standard)
Door Fire Rating	E120 available if required
Control System	Call and send controls at entrance for goods only. If trained operator, control panel is located on inside of lift car
Flooring	Checker plate
Tube Lighting	On ceiling bar
Car Sizes	Width 1000 - 2000 mm / Depth 1200 - 3000 mm / Height 1800 - 2500 mm
Drive System	Twin heavy duty chains
Motor	Located within head of shaft
Power Supply	400 V 3-phase, 50 Hz, neutral & earth
Motor	3 kW / 4 kW / 5,5 kW (dependent upon capacity of lift)
Motor Starts (per hour)	30



Foot activated roll stop unit – flat



Foot activated roll stop unit – upright



Interior of goods only model with ceiling lighting bar above

Thorax Goods Lift



Goods and trained operator model, showing full car ceiling and lights

- SW - Shaft Width
- CW - Car Width
- DH - Door Height
- CH - Car Height
- DW - Door Width
- SD - Shaft Depth
- CD - Car Depth

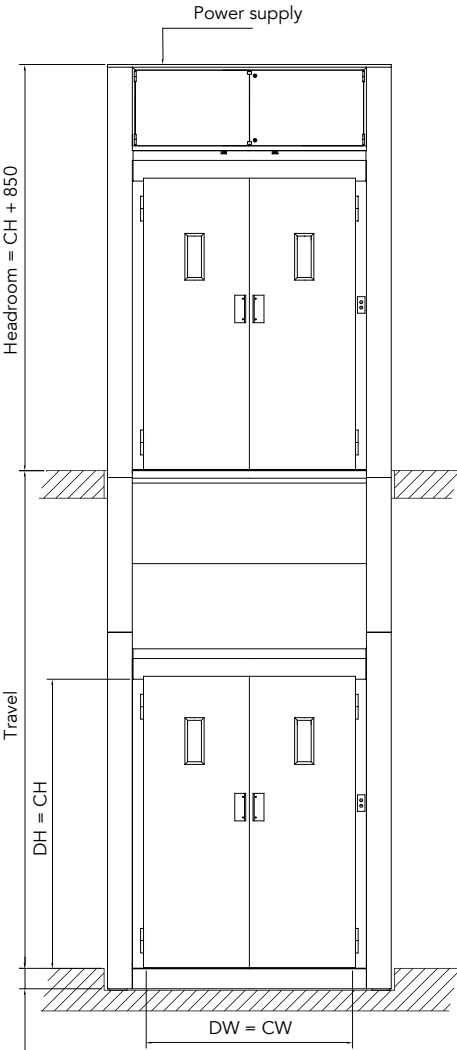

Pit depth TBC dependent on model selected (or ramp if you prefer)

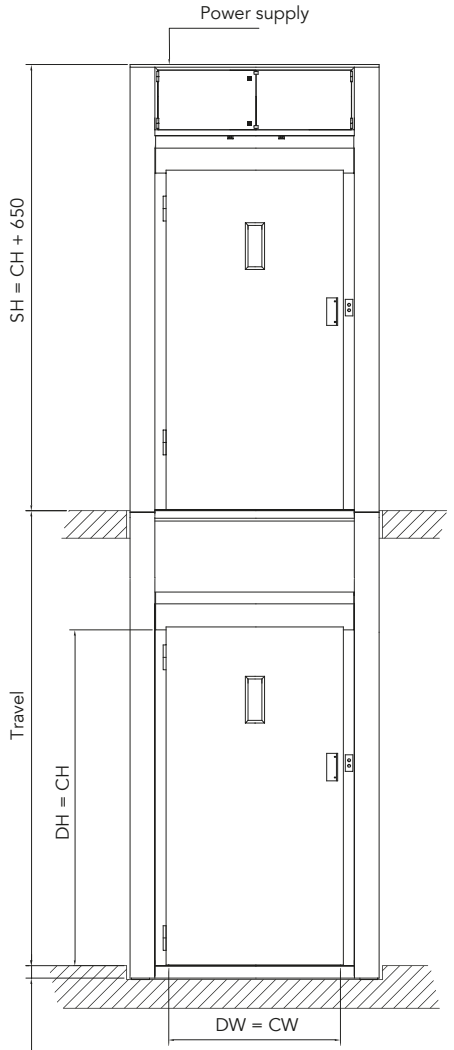
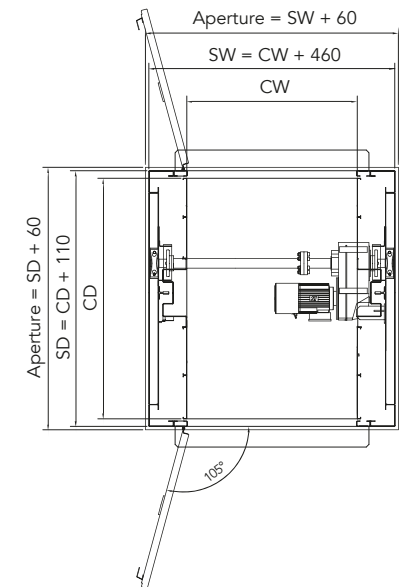
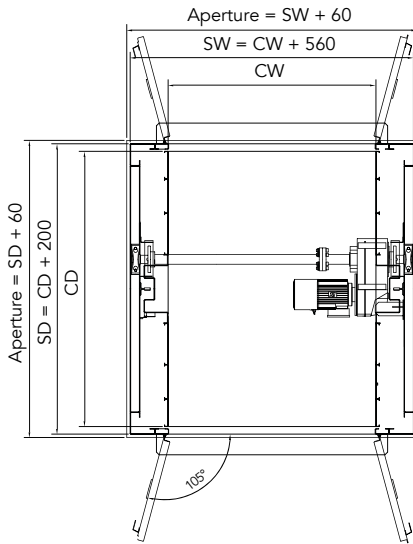

Pit depth TBC dependent on model selected (or ramp if you prefer)

Thorax Goods Lift



Motor and twin heavy duty chain drive system



Access to controller above top landing doors. Installation comes complete with aluminium access ladder

Landmark Lifts Limited

29 Charter Gate
Quarry Park Close
Moulton Park
Northampton
NN3 6QB
United Kingdom

t: 01604 671007

f: 01604 671017

e: info@landmarklifts.co.uk

w: www.landmarklifts.co.uk

Part of the NLC Nova Group

Our marketing literature is presented in good faith as a guide to represent the product offered and does not form a part of our contract.



Landmark Lifts 

